

Installation Instructions for CP100, IP100 and NP100 Series Gas Control Panels

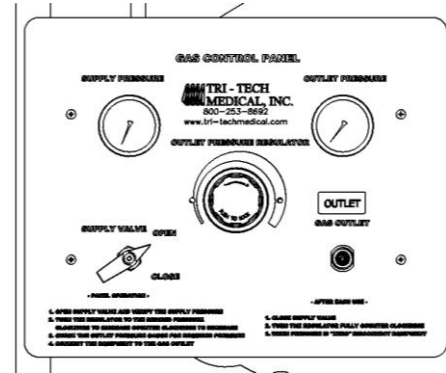

Installation of the Gas Control Panel involves installing the rough-in box and making the necessary piping connections in accordance with NFPA 99.

Warning this device should only be installed by qualified personnel. Installation should not be attempted by anyone not having general experience with the installation of devices of this nature.

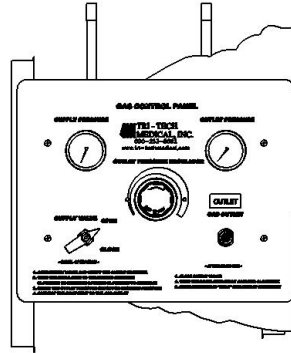
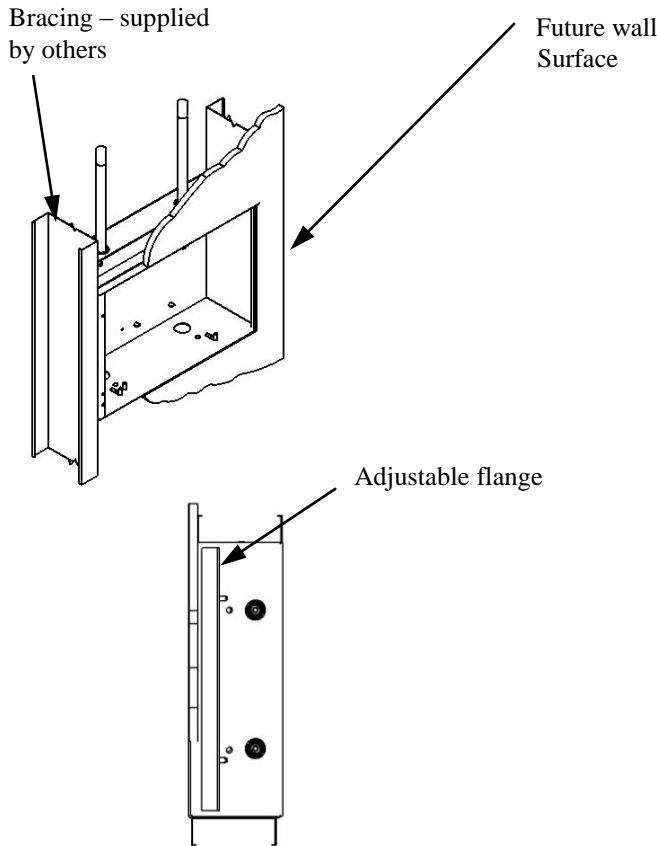

Step #1 – Provide rigid mounting that will support the gas control panel back box on the top and bottom. (Rigid mounting materials are not included with the panel). Refer to the building plans to determine location of the panel. Mount back box so it will be flush or just below the finished wall surface. Remove dust cover from back box only when the finished wall surface is complete and you are ready to install the front panel.

Step #1a – Adjustable flanges have been provided on both the top (shown here) and bottom of the back box. Loosen the screws from the inside of the back box to allow the back box to be adjusted so that it is flush or slightly recessed with the finished wall surface.

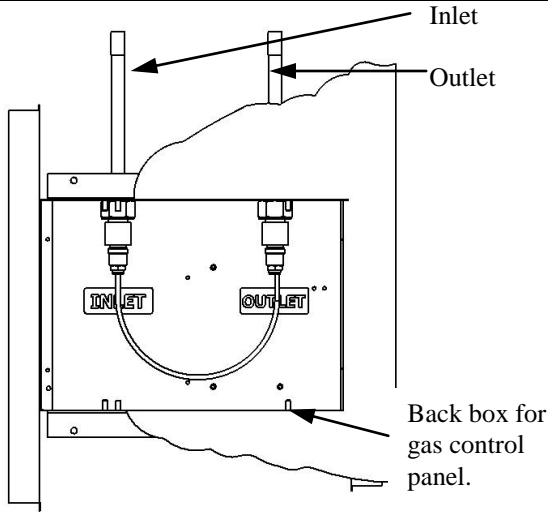
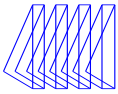

Step #2 – Connect the inlet & outlet copper extension tubes to the gas piping system. Make sure drop is for the proper gas service. Using a purge gas to insure cleanliness in the tubes, silver braze the joints. **Do not use soft solder!** (See NFPA 99 for recommended silver braze alloys). Conduct heat away from the back box. It is recommended that gas piping system tubing be connected from the outlet copper extension tube to the ceiling and capped, even though a continuation of this system may not be intended at this time.

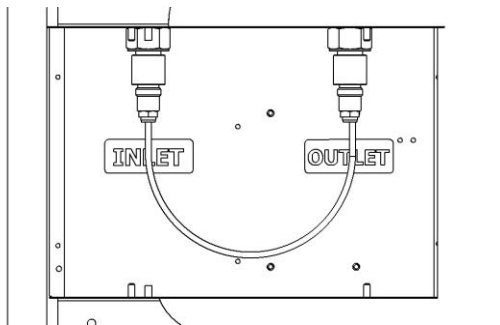

Note – The inlet and outlet extension tubes have been pre-piped together at the factory to allow for the required 150 psi standing pressure test.

Step #3 – Remove the dust cover when the finished wall surface is complete and you are ready to install the front panel.

to connect

to disconnect

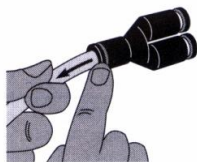
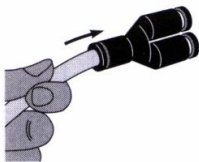

Simply push the tubing until it can go no further. Holding and sealing is accomplished instantaneously.

First depress the manual release button, then pull the tubing out of the fitting.

Step 4 – The tubing and fittings provided in this panel should be connected and disconnected by hand – without the use of tools.

Wash your hands before handling these connections to ensure that oil, grease, dirt etc. do not contaminate the fittings possibly causing leakage and introducing impurities into the medical gas system.

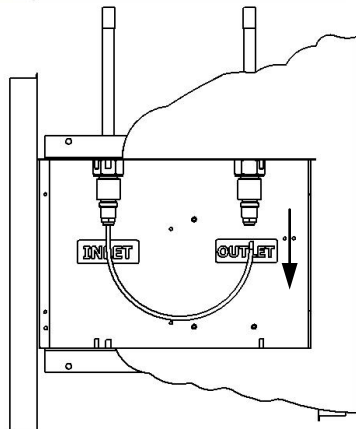

Step 5 – Disconnect the gas outlet tube from the fitting inside the back box.

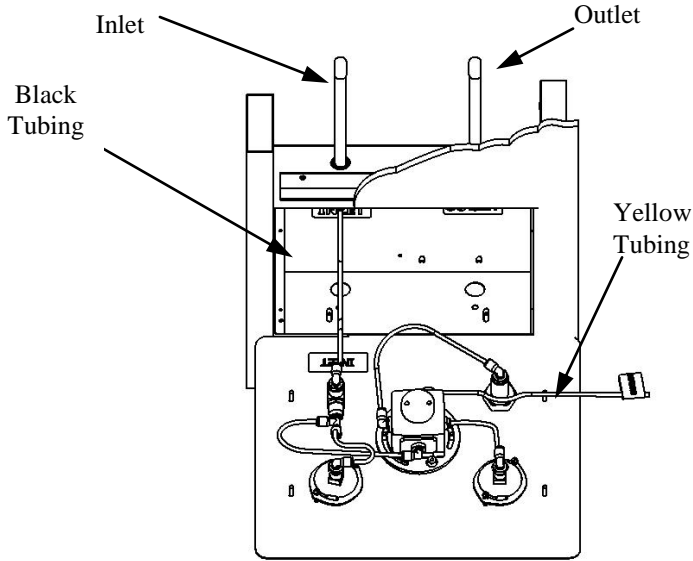
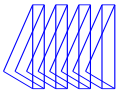

Step 6 – Insert the end of the black tube that you just disconnected from the gas outlet fitting into the gas inlet fitting on the back of the valve on the front panel.

Step 7 – Insure tubing connections are properly made by tugging on the tubing with slight pressure

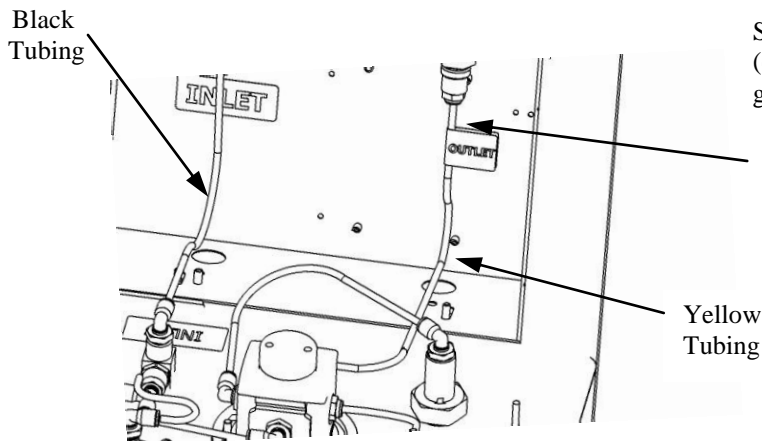

Step 8 – Insert the unconnected yellow tube (coming off the bottom of the regulator) into the gas outlet fitting in the back box.

Step 9 – Again, insure tubing connections are properly made by tugging on the tubing with slight pressure.

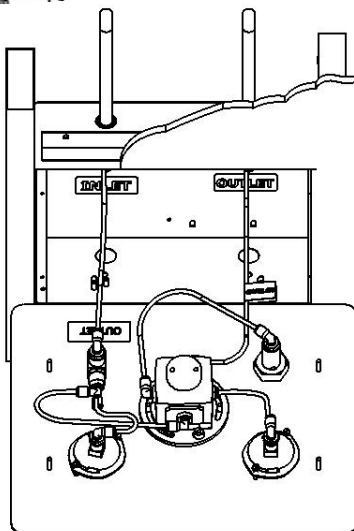

Step 10 – Finished tubing connections should look like this.

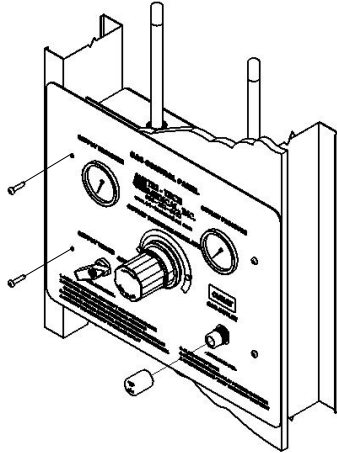
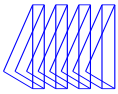

Step 11 – Attach the front panel to the back box (using the 4 long screws provided). Be careful not to pinch or damage tubing. The tubing connectors swivel to ease installation. And remove shipping cap.

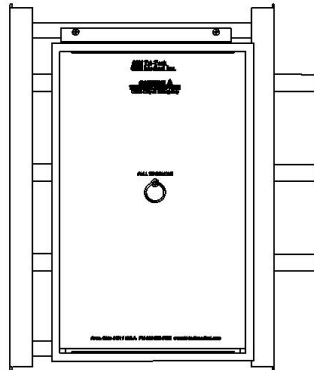

Step 12 – The Gas Control panel should now be ready for testing and use. To restore gas service to the panel, locate and open the zone valve providing gas to the gas control panel.

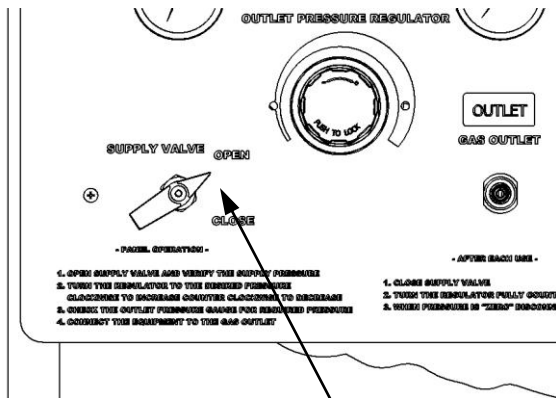

Step 13 – Use the Supply Valve on the gas control panel to control gas flow to the panel and equipment connected downstream of the panel.

Turn up to open.

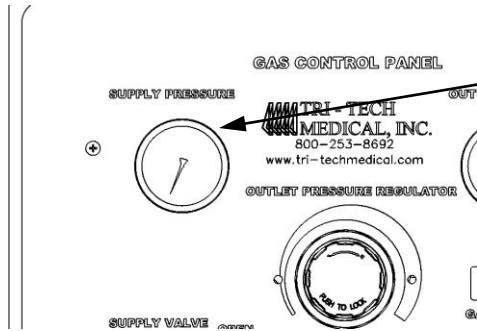
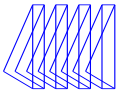

Step 14 – A Supply Pressure Gauge (or Inlet Pressure Gauge) is provided to allow monitoring of the pressure being supplied to the gas control panel. The pressure shown on this gauge will match the pressure shown at the zone valve box provided the Supply Valve on the gas control panel is ON or open.

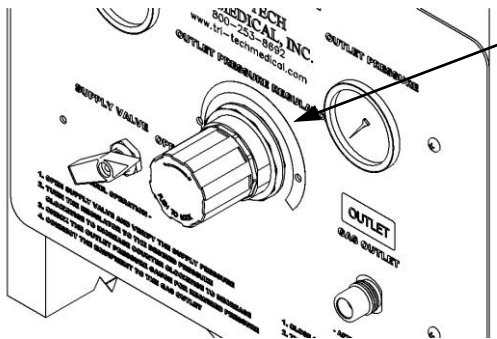

Step 15 – The Outlet Pressure Regulator adjusts or regulates the delivery pressure of the gas. Turning the knob clockwise increases the delivery pressure. Turning the knob counterclockwise decreases the delivery pressure. The regulator is self venting which means a small amount of gas will be allowed to escape through the regulator bonnet when the delivery pressure is decreased.

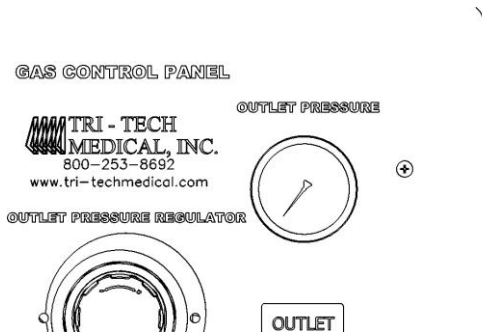

Step 16 – The Outlet Pressure Gauge displays the delivery or outlet pressure as controlled by the regulator.

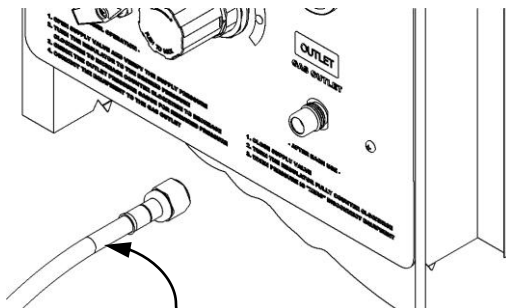

Step 17 – The Gas Outlet allows connection of DISS Gas hose assemblies. The outlet connection provides a demand check valve which automatically stops the flow of gas when the hose is disconnected. The Gas Control Panel is now ready for use!

DISS Connections